

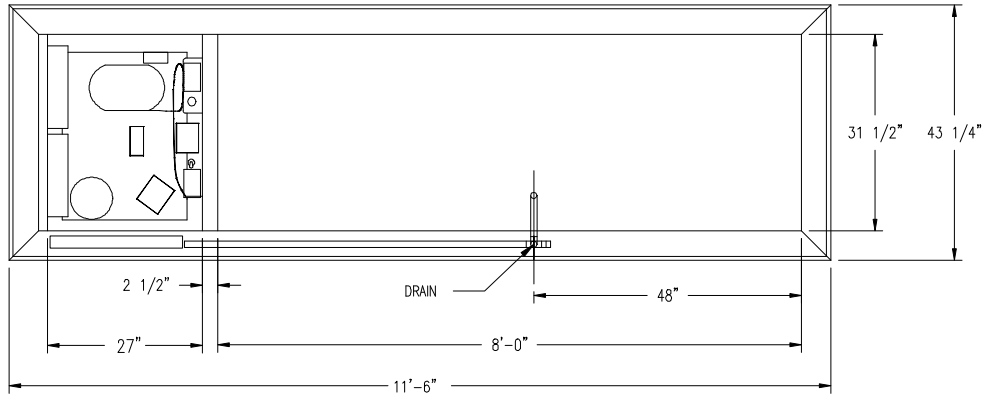

# SELF-CONTAINED ISLAND SPECIFICATION SHEET

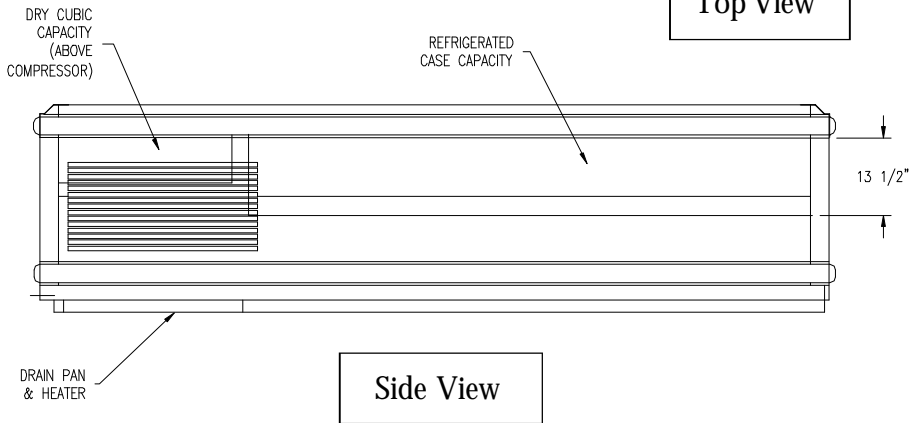

Top View



Side View

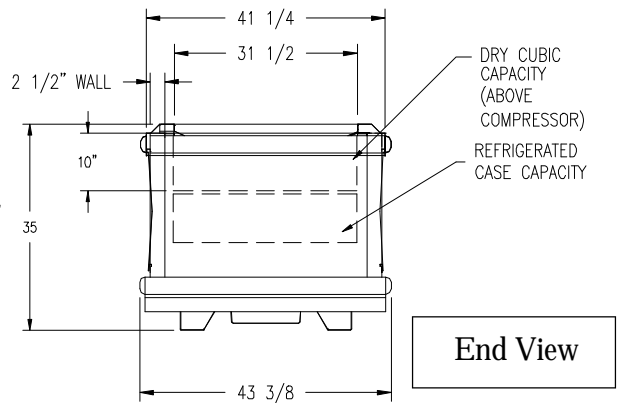

End View

MODEL NUMBER	EVAP. TEMP.	ANTI-SWEAT		FANS		DEFROST		COMPRESSOR			
		VOLTS	AMPS	NO.	VOLTS	AMPS	VOLTS	AMPS	RLA	H.P.	VOLTS
IM - (FREEZER/COOLER) IMD - (DUAL TEMP)	-25° F	115	2.44	2	115	1	220	7.1	25.4	2	208/230
	+15° F										
<b>TOTAL ELECTRICAL: 115/208-230V - 1 PHASE - 60 HZ AMPS: 28.84</b> <b>NOTE: TYPICAL BRANCH CIRCUIT: 40 AMP 3 WIRE W/GROUND</b>											

OVERALL CASE LENGTH	REFRIGERATED CASE LENGTH	DISPLAY CAPACITY	DISPLAY AREA	DRY STORAGE CAPACITY	DRY STORAGE AREA	APPROX. SHIPPING WEIGHT
11' - 6"	8'	26.3 CU. FT.	21 SQ. FT.	5.29 CU. FT.	6.34 SQ. FT.	1,198 LBS.

61 Broadway, Suite 1900  
 New York, NY 10006  
 PH: (212)-898-9699 FAX: (212)-514-9234  
 bmil@bmil.com



Zero Zone, Inc. • 110 N. Oakridge Dr.  
 North Prairie, WI 53153-9792  
 1-800-247-4496 • FAX: 1-414-392-6450  
 www.zero-zone.com

All specifications are subject to change without notice.